

E100PN10

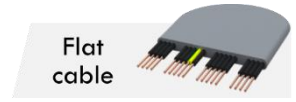

Single layer	
Fix centring	2 Heating zone(s)

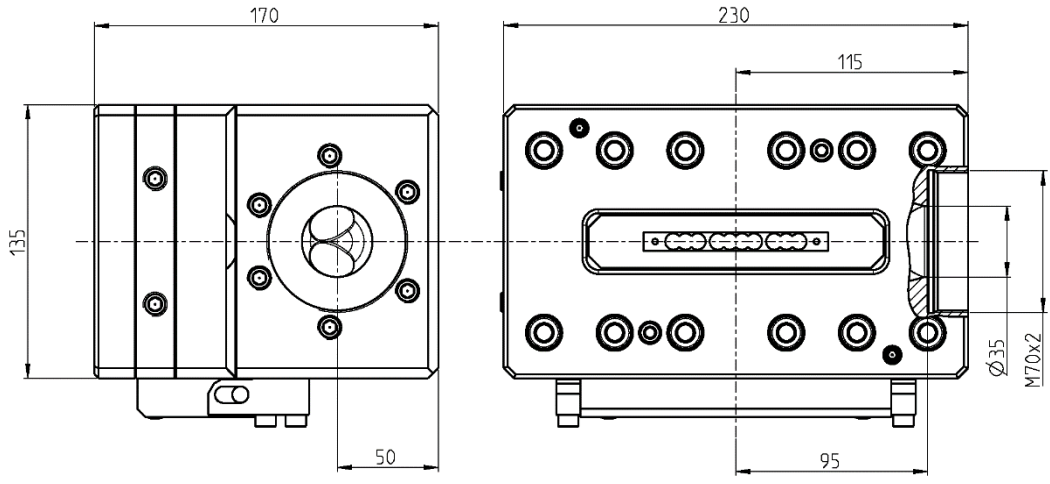
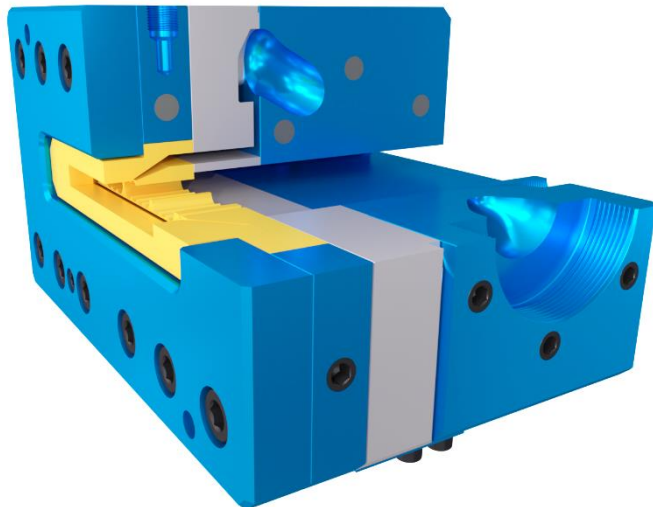

Version	Maximum opening of the Tip	Maximum opening of the Die	Main entry port / thread		Auxiliary entry port / thread		Total length	Crosshead diameter	Max. working temperature	Max. working pressure	Weight
			A	B	C	D					
-	100x9 mm	102x11 mm	35 mm	M70x2	-	-	170 mm	135 mm	<400°C	400 bars	38 kg

Options

Vacuum connection	Extruder connection	Bypass module	Trolley or stand	Customized distributor					