







# E120PN10

 Single layer	
 Fix centring	 2 Heating zone(s)

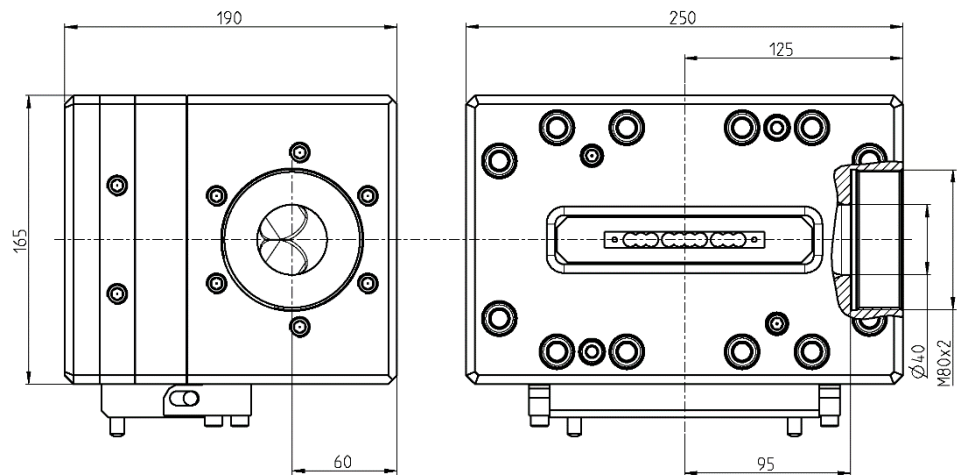
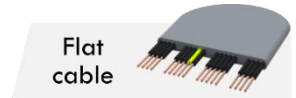
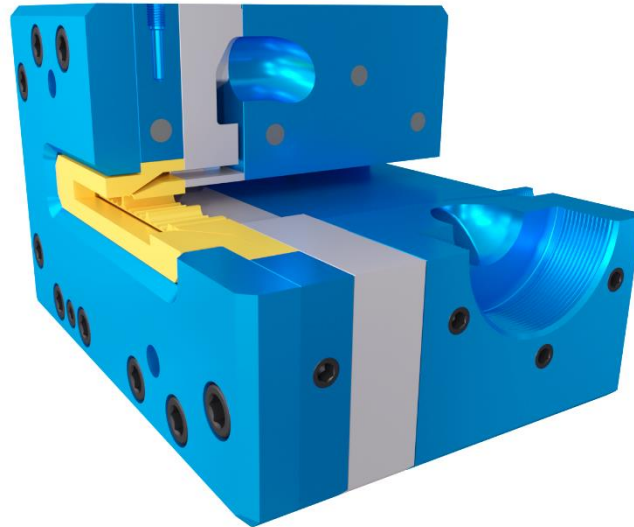

Version	Maximum opening of the Tip	Maximum opening of the Die	Main entry port / thread		Auxiliary entry port / thread		Total length	Crosshead diameter	Max. working temperature	Max. working pressure	Weight
			A	B	C	D					
-	112x9 mm	120x13 mm	40 mm	M80x2	-	-	190 mm	165 mm	<400°C	400 bars	55 kg

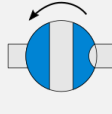
## Options

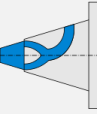
 Vacuum connection	 Extruder connection	 Bypass module	 Trolley or stand	 Customized distributor					
--	--	--	---	---	--	--	--	--	--