

E12BF11

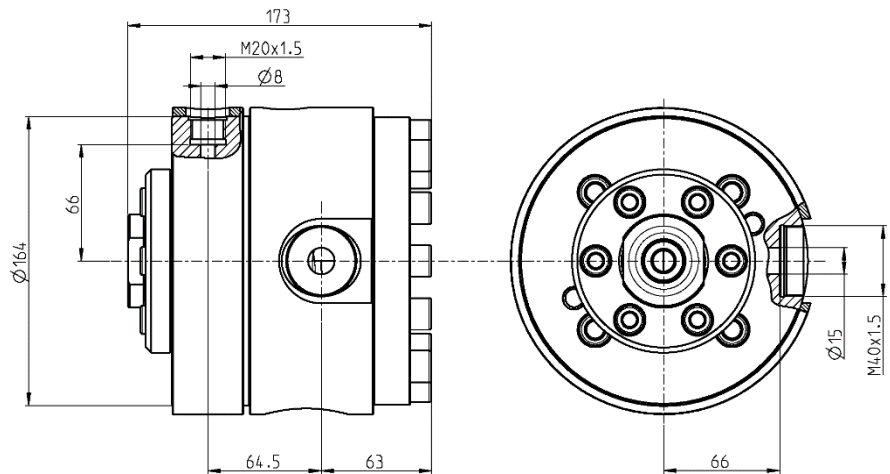

| Version | Maximum opening of the Tip | Maximum opening of the Die | Main entry port / thread | | Auxiliary entry port / thread | | Total length | Crosshead diameter | Max. working temperature | Max. working pressure | Weight |
|---------|----------------------------|----------------------------|--------------------------|---------|-------------------------------|---------|--------------|--------------------|--------------------------|-----------------------|--------|
| | | | A | B | C | D | | | | | |
| - | 14 mm | 20 mm | 15 mm | M40x1.5 | 8 mm | M20x1.5 | 173 mm | 164 mm | <400°C | 400 bars | 24 kg |

Options

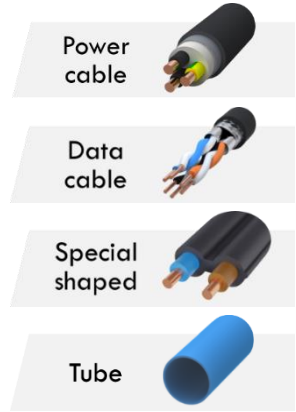
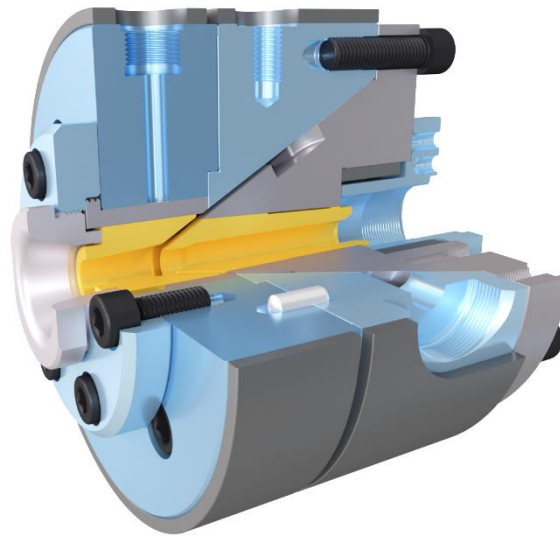
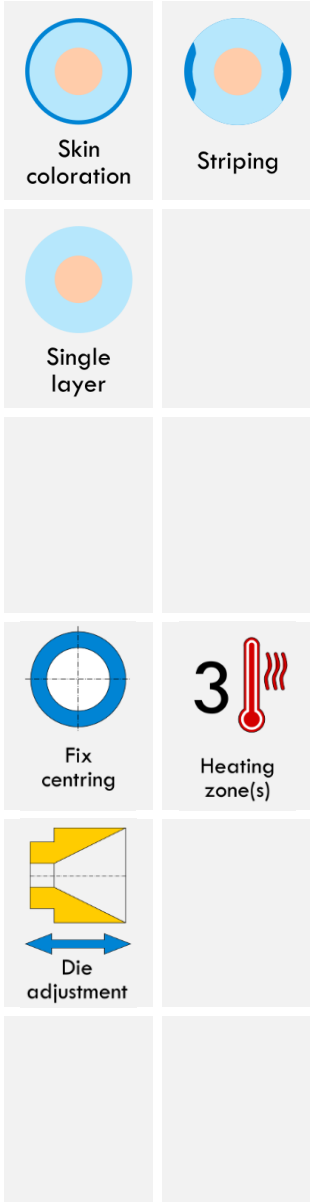