









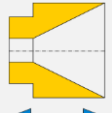
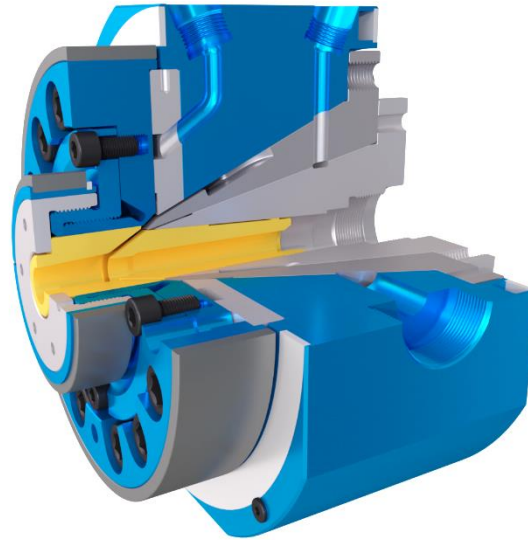

E12HN30

 SFS	 Skin coloration
 Striping	 Single layer
FT Fine-tuning centring	 2+ Heating zone(s)
 Die adjustment	





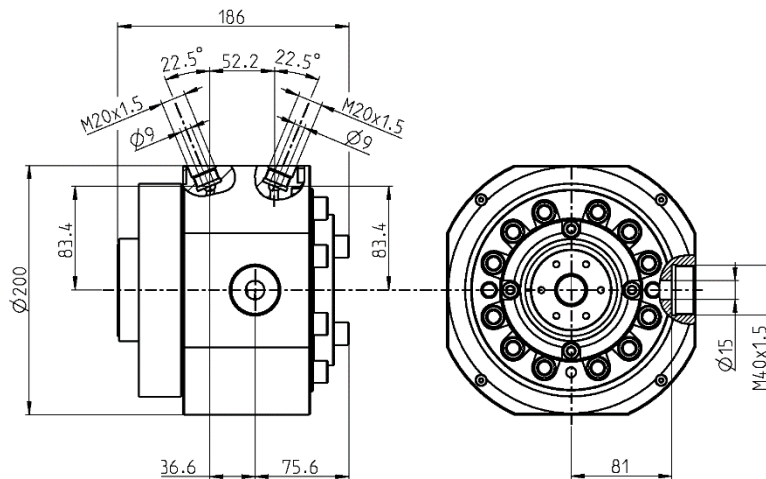

- Power cable 
- Data cable 
- Special shaped 
- Tube 
- Multi-layer tube 
- Foamed cable 

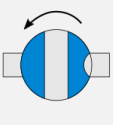

Version	Maximum opening of the Tip	Maximum opening of the Die	Main entry port / thread		Auxiliary entry port / thread		Total length	Crosshead diameter	Max. working temperature	Max. working pressure	Weight
			A	B	C	D					
-	14 mm	20 mm	15 mm	M40x1.5	9 mm	M20x1.5	186 mm	200 mm	<400°C	600 bars	34 kg

Options

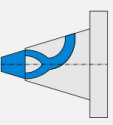
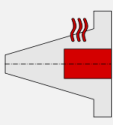
 Vacuum connection	 Extruder connection	 Bypass module	 Trolley or stand	 Customized distributor	 Heated distributor					
--	--	--	---	---	---	--	--	--	--	--