







E14AN10

 Single layer	
 Fix/manual centring	 2 Heating zone(s)
 Die adjustment	 Tip adjustment

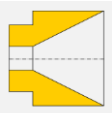
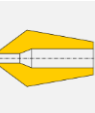
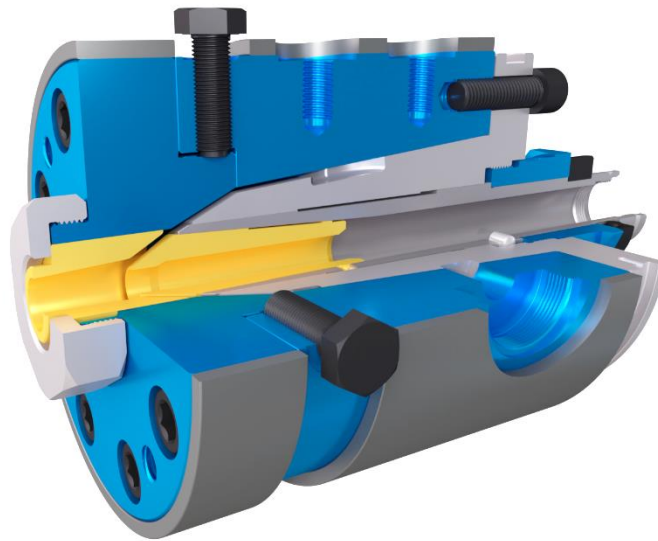



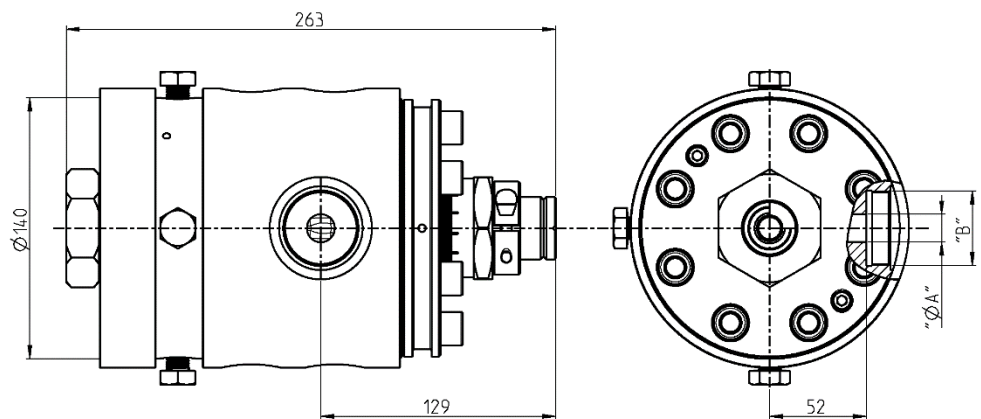



Power cable	
Data cable	
Special shaped	
Tube	

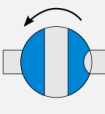
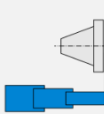

Version	Maximum opening of the Tip	Maximum opening of the Die	Main entry port / thread		Auxiliary entry port / thread		Total length	Crosshead diameter	Max. working temperature	Max. working pressure	Weight
			A	B	C	D					
Normal	14 mm	20 mm	15 mm	M40x1.5	-	-	263 mm	140 mm	<250°C	600 bars	24 kg
HFFR			20 mm	M50x1.5							

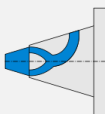
Options

 Vacuum connection	 Extruder connection	 Bypass module	 Telescopic maintenance device	 Trolley or stand	 Customized distributor	 300°C Reinforced heaters			
--	--	--	--	---	---	--	--	--	--