

# E14AN11

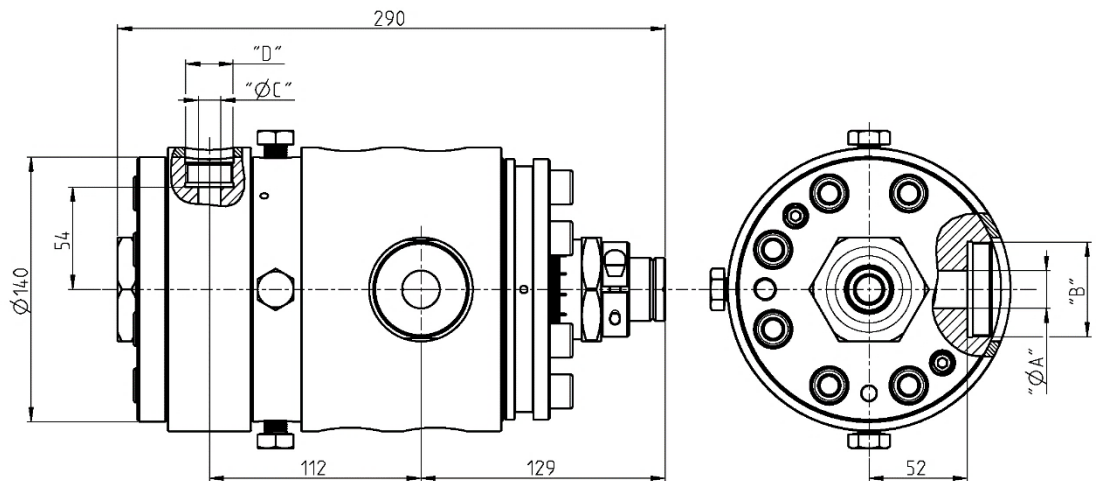

Version	Maximum opening of the Tip	Maximum opening of the Die	Main entry port / thread		Auxiliary entry port / thread		Total length	Crosshead diameter	Max. working temperature	Max. working pressure	Weight
			A	B	C	D					
Normal	14 mm	20 mm	15 mm	M40x1.5	8 mm	M20x1.5	290 mm	140 mm	<250°C	600 bars	27 kg
HFFR			20 mm	M50x1.5	12 mm	M25x1.5					

## Options

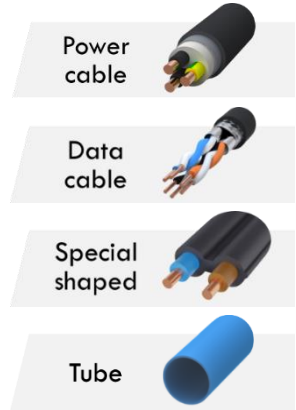
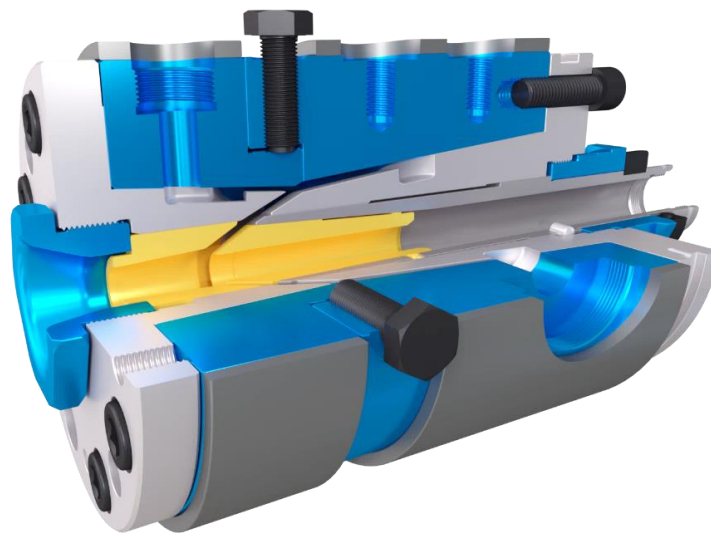
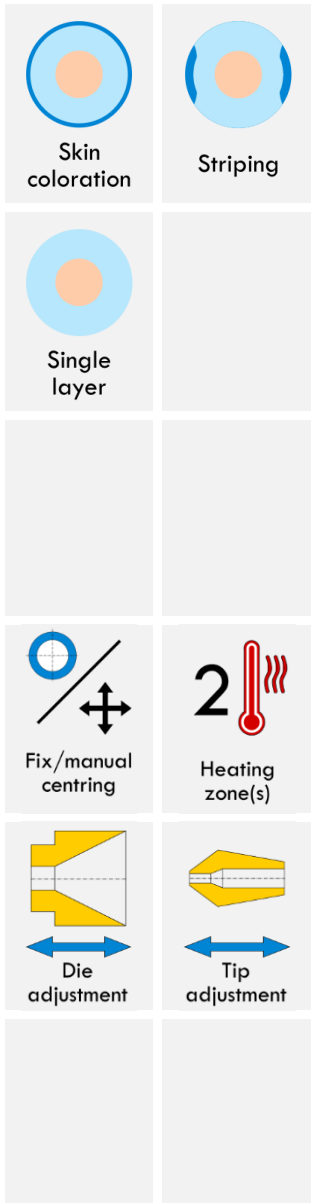