

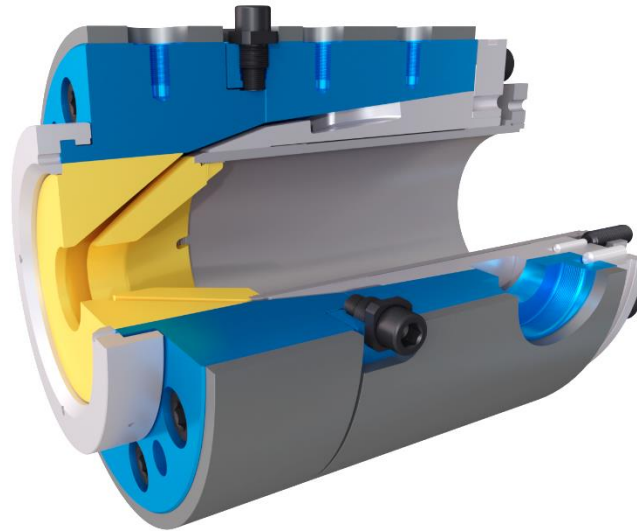





# E180AN10

 Single layer	
 Manual centring	 2 Heating zone(s)
 Die adjustment	 Tip adjustment





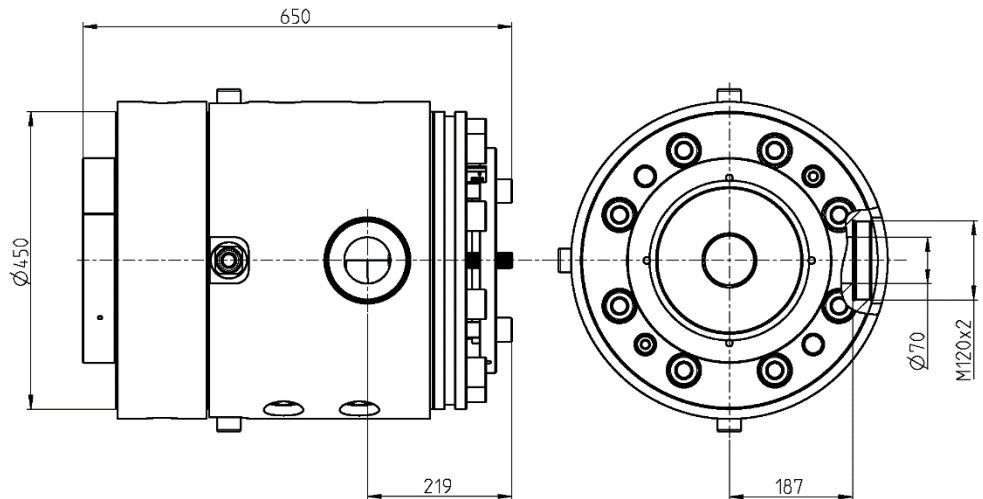



Power cable	
Data cable	
Special shaped	
Tube	
HV/MV cable	

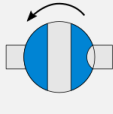
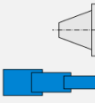

Version	Maximum opening of the Tip	Maximum opening of the Die	Main entry port / thread		Auxiliary entry port / thread		Total length	Crosshead diameter	Max. working temperature	Max. working pressure	Weight
			A	B	C	D					
-	180 mm	190 mm	70 mm	M120x2	-	-	650 mm	450 mm	<250°C	400 bars	560 kg

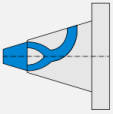
## Options

 Vacuum connection	 Extruder connection	 Bypass module	 Telescopic maintenance device	 Trolley or stand	 Customized distributor	 300°C Reinforced heaters				
----------------------------------------------------------------------------------------------------------	------------------------------------------------------------------------------------------------------------	------------------------------------------------------------------------------------------------------	----------------------------------------------------------------------------------------------------------------------	---------------------------------------------------------------------------------------------------------	---------------------------------------------------------------------------------------------------------------	------------------------------------------------------------------------------------------------------------------	--	--	--	--