









E20LN21

 Skin coloration	 Striping
 Single layer	
 Manual centring	 2 Heating zone(s)
 Die adjustment	

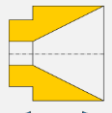
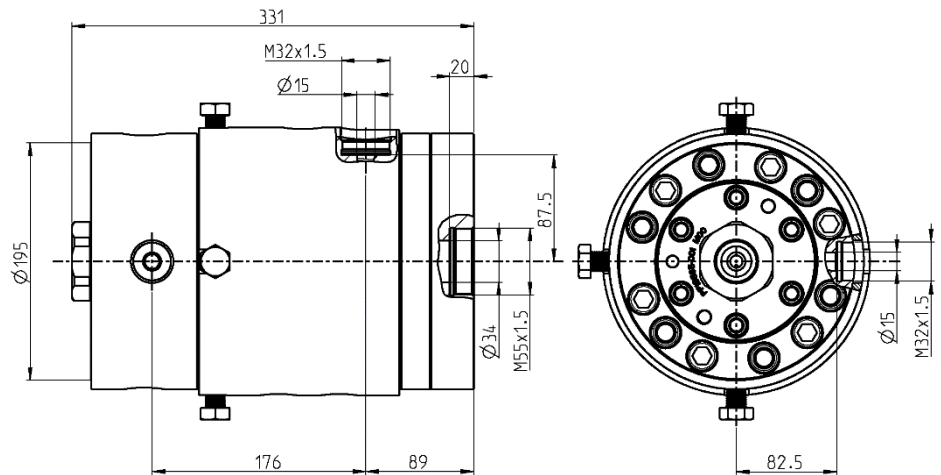
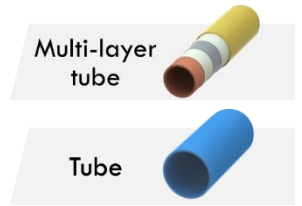
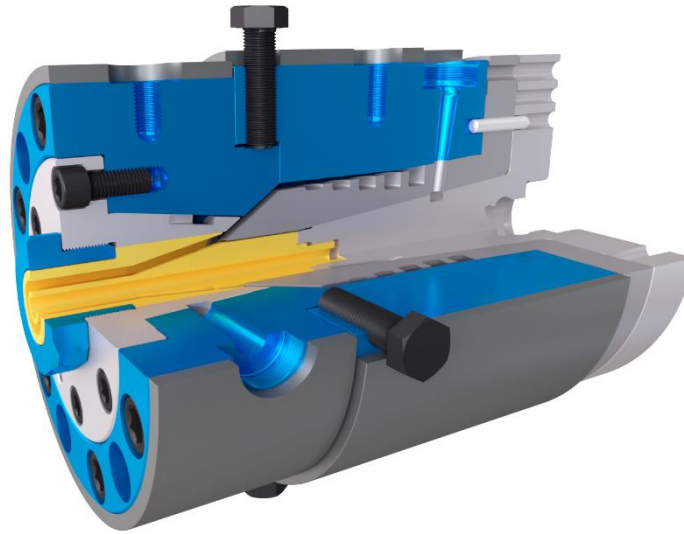

Version	Maximum opening of the Tip	Maximum opening of the Die	Main entry port / thread		Auxiliary entry port / thread		Total length	Crosshead diameter	Max. working temperature	Max. working pressure	Weight
			A	B	C	D					
-	-	20 mm	34 mm	M55x1.5	15 mm	M32x1.5	331 mm	195 mm	<250°C	500 bars	80 kg

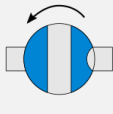
Options

 Vacuum connection	 Extruder connection	 Bypass module	 Trolley or stand	 300°C Reinforced heaters						
--	--	--	---	---	--	--	--	--	--	--