







E2AN10 FIX

 Single layer	
 Fix centring	 1 Heating zone(s)
 Die adjustment	

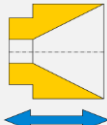
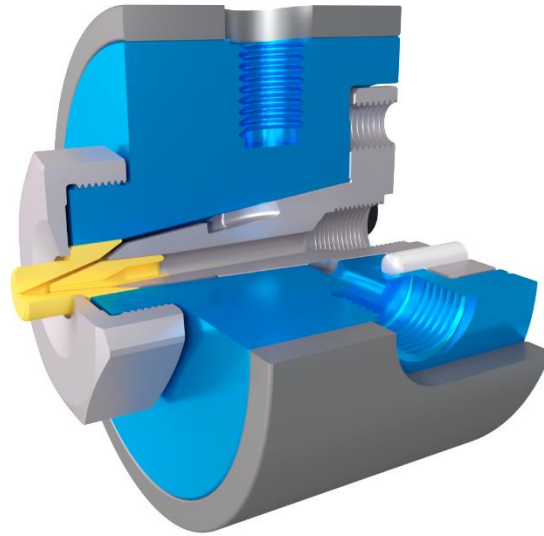



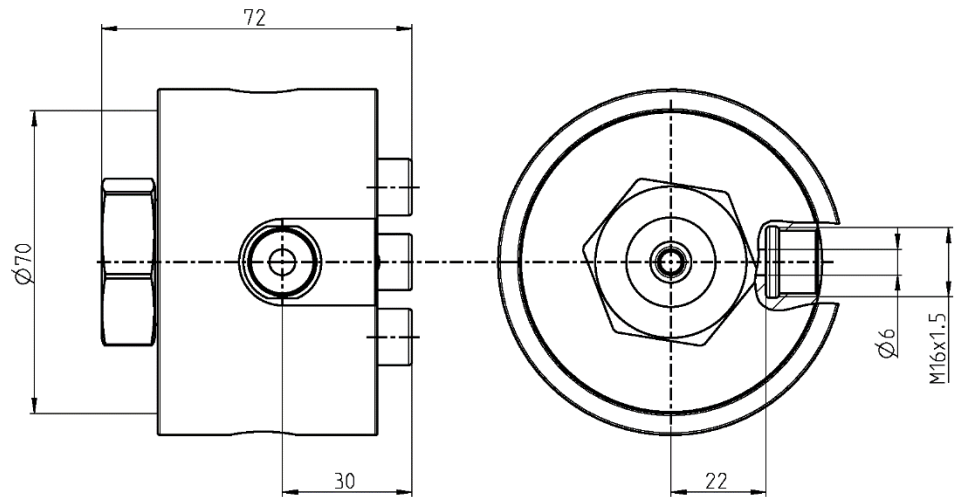



- Power cable 
- Data cable 
- Special shaped 
- Tube 

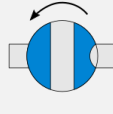

Version	Maximum opening of the Tip	Maximum opening of the Die	Main entry port / thread		Auxiliary entry port / thread		Total length	Crosshead diameter	Max. working temperature	Max. working pressure	Weight
			A	B	C	D					
-	2 mm	5 mm	6 mm	M16x1.5	-	-	72 mm	70 mm	<250°C	600 bars	2 kg

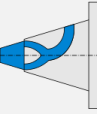
Options

 Vacuum connection	 Extruder connection	 Bypass module	 Trolley or stand	 Customized distributor	 300°C Reinforced heaters					
--	--	--	---	---	---	--	--	--	--	--