









E4AN11 MAN

 Skin coloration	 Striping
 Single layer	
 Manual centring	 2 Heating zone(s)
 Die adjustment	

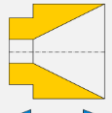



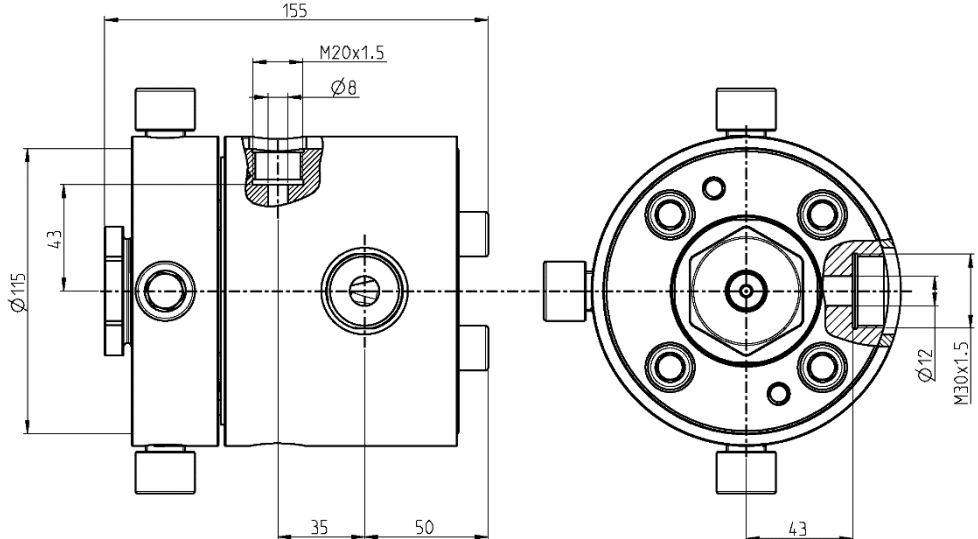

- Power cable 
- Data cable 
- Special shaped 
- Tube 

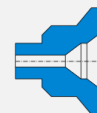
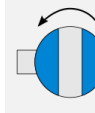

Version	Maximum opening of the Tip	Maximum opening of the Die	Main entry port / thread		Auxiliary entry port / thread		Total length	Crosshead diameter	Max. working temperature	Max. working pressure	Weight
			A	B	C	D					
-	7 mm	11 mm	12 mm	M30x1.5	8 mm	M20x1.5	155 mm	115 mm	<250°C	750 bars	10 kg

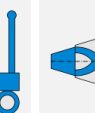
Options

 Vacuum connection	 Extruder connection	 Bypass module	 Telescopic maintenance device	 Trolley or stand	 Customized distributor	 300°C Reinforced heaters				
--	--	--	--	---	---	---	--	--	--	--